



Site Preparation Specification

Purpose of Procedure

Your site must meet this specification or set of requirements to assure a successful and timely installation of your Agilent instrumentation. This document is designed to prevent delays during installation, familiarization, and the initial use of the system in your application. This document outlines the supplies, consumables, space and utility requirements for an 1100 LC. It also recommends tools and consumables that may help you get started. Use this document along with the 1100 Installation documentation and Consumable Catalog. This information is also available from Agilent Technologies, Inc.'s website (<http://www.agilent.com>).

Customer Responsibilities

Make sure your site meets this specification, including: the necessary space, electric outlets, gases, tubing, operating supplies, consumables and other usage dependent items such as columns, vials, syringes and solvents (HPLC Grade Isopropanol, Acetonitrile and water) required for the successful installation of instruments and systems. If Agilent is delivering installation and familiarization services, users of the instrument should be present throughout these services; otherwise, they will miss important operational, maintenance and safety information.

Important Information

If you have problems in providing anything described as a *Customer Responsibility*, please contact your local Agilent Technologies office for assistance. Assistance with user specific applications may be provided but should be contracted separately.

PLEASE NOTE:

Some of the instrumentation, you have ordered, may not appear on the following tables, because some of the individual modules that generate a system are not sold as individual parts.

For example, if you ordered a:

- G1327A, you will receive a G1329A (Autosampler) and a G1330B (ALS Thermostat)
- G1354A, you will receive a G1311A (Quat. Pump) and a G1379A (Micro Vacuum Degasser)
- G1368A, you will receive a G1367A (Wellplate-Autosampler) and a G1330B (ALS Thermostat)
- G1378A, you will receive a G1377A (Micro-Wellplate-Autosampler) and a G1330B (ALS Thermostat)
- G1387A, you will receive a G1389A (Micro-Autosampler) and a G1330B (ALS Thermostat)
- G2261A, you will receive a G2260 (Preparative-Autosampler) and a G1330B (ALS Thermostat)

If you have ordered a bundled system or if you have problems in identifying the individual modules that are part of your system, please contact your sales representative for information about the individual modules that generate this system.



Site Preparation Specification



Dimensions and Weight

Select the laboratory bench space before your system arrives. Pay special attention to the total height requirements. Avoid bench space with overhanging shelves. Pay special attention to the total weight of the modules you have ordered. Make sure that your laboratory bench can support this weight.

Module	Weight		Height		Depth		Width	
G1310A/G1311A Iso. / Quat. Pumps	11 kg	25 lbs.	14 cm	5.5 in	43.5 cm	17 in	34.5 cm	13.5 in
G1312A Binary Pump	15.5 kg	34 lbs.	18 cm	7 in	43.5 cm	17 in	34.5 cm	13.5 in
G1376A/G2226A Capillary/Nano Pump	17 kg	39 lbs.	18 cm	7 in	43.5 cm	17 in	34.5 cm	13.5 in
G1322A / G1379A Degassers	7.5 kg	16.5 lbs.	8 cm	3 in	43.5 cm	17 in	34.5 cm	13.5 in
G1361A / G1391A Preparative Pumps	15 kg	32.9 lbs.	20 cm	8 in	43.5 cm	17 in	34.5 cm	13.5 in
G1313A/G1329A/G1389A/ G2260A Autosamplers	14.2 kg	31.3 lbs.	20 cm	8 in	43.5 cm	17 in	34.5 cm	13.5 in
G1367A/G1377A Well Plate Samplers	15.5 kg	34.2 lbs.	20 cm	8 in	43.5 cm	17 in	34.5 cm	13.5 in
G1330A/B ALS Thermostats	18.5 kg	40.7 lbs.	14.4 cm	5.5 in	43.5 cm	17 in	34.5 cm	13.5 in
G1316A Thermostatted Column Compartment	10.2 kg	22.5 lbs.	14 cm	5.5 in	43.5 cm	17 in	41 cm	16 in
G1157A/G1158A/G1159A/ G1160A/G1162A/G1163A Valves	1.9 kg	4.2 lbs.	9.2 cm	3.6 in	20 cm	8 in	8.4 cm	3.3 in
G1314A Variable Wavelength Detector	11 kg	25 lbs.	14 cm	5.5 in	43.5 cm	17 in	34.5 cm	13.5 in
G1315A/B Diode-Array Detectors	11.5 kg	26 lbs.	14 cm	5.5 in	43.5 cm	17 in	34.5 cm	13.5 in
G1365A/B Multiple Wavelength Detectors	11.5 kg	26 lbs.	14 cm	5.5 in	43.5 cm	17 in	34.5 cm	13.5 in
G1321A Fluorescence Detector	11.5 kg	25.4 lbs.	14 cm	5.5 in	43.5 cm	17 in	34.5 cm	13.5 in
G1362A Refractive Index Detector	17 kg	38 lbs.	18 cm	7 in	43.5 cm	17 in	34.5 cm	13.5 in
G1364A Fraction Collector	17 kg	38 lbs.	18 cm	7 in	43.5 cm	17 in	34.5 cm	13.5 in



Site Preparation Specification



Environmental Conditions



Operating the LC System within the recommended temperature ranges insures optimum instrument performance and lifetime. Performance can be affected by sources of heat and cold from heating, air conditioning systems, or drafts.

Please Note:

The site's ambient temperature conditions must be stable for optimum performance of the system's modules (as specified in the "Performance Specifications" section of each module's Reference Manual). Temperature changes of 2°C / hour or less (as defined by ASTM conditions) are required to achieve best possible baseline stability. Higher variations will definitely result in higher signal drift and wander of the baseline.

Module	Operating temp range	Operating humidity range
<i>G1314A, G1315A/B, G1365A/B & G1362A</i>	0 to 55°C (32 to 131°F), constant temperature.	< 95%, non-condensing
<i>G1330A/B, G1361A, G1391A</i>	4 to 40°C (39 to 104°F)	< 95%, non-condensing
<i>G1321A</i>	0 to 40°C (32 to 104°F), constant temperature	< 95%, non-condensing
<i>All other modules</i>	4 to 55°C (39 to 131°F), constant temperature.	< 95%, non-condensing



Power Consumption



PLEASE NOTE:

An AC power outlet is required for EACH module, in addition to the Computer System (if applicable)

All Agilent 1100 modules have automatic line sensing, wide ranging power supplies. All modules operate with line voltages in the range of 100-240 VAC, +/- 10%

Module	Maximum Power Consumption [VA]	Maximum Power Consumption [W]	BTU
G1310/11A Iso. / Quat. Pumps	180 VA	55 W	188
G1312A Binary Pump	220 VA	74 W	253
G1376A/G2226A Capillary/Nano Pump	220 VA	75 W	256
G1361A / G1391A Prep Pumps	250 VA	210 W	717
G1379A Micro Degasser	30 VA	30 W	102
G1322A Degasser	30 VA	30 W	102
G1313A Autosampler	85 VA	180 W	290
G1329A, G1389A, G2260A Autosamplers	300 VA	200 W	683
G1367A/G1377A Well Plate Autosamplers	300 VA	200 W	683
G1330A/B Sample Thermostat	260 VA	210 W	717
G1316A Therm Column Comp	320 VA	150 W	512
G1314A VWD	220 VA	85 W	290
G1315A/B DAD	300 VA	125 W	427
G1365A/B MWD	300 VA	125 W	427
G1362A RID	160 VA	65 W	222
G1321A FLD	180 VA	70 W	239
G1364 Fraction Collector	200 VA	180 W	614

Site Preparation Specification



Other considerations



Module Stacking

Bench Space:

The modular dimensions and weight allow the instrument to be placed on almost any laboratory bench. The instrument requires a space of at least 2.5 cm (1.0 inch) on both sides, and approximately 8 cm (3.1 inches) at the rear for the circulation of air and room for electrical connections.

If the bench is to support a complete Agilent Technologies 1100 Series system, make sure that the bench is designed to carry the total weight of all the modules.

Ensure that all 1100 series modules are installed and operated in a horizontal position. Operating a module on its side will defeat the leak detection system of the module and possibly cause a hardware failure within the module.

Recommended Stacking Configurations:

A single-stack configuration may be considered only if:

- * The height of the stack does not result in a safety problem.
- * The system does not include a G1330A/B thermostat module.

A multiple stack configuration **must** be used if:

- * The stack of 1100 modules is too high, resulting in a safety problem.
- * The system includes a thermostatted sampler or fraction collector.

PLEASE NOTE:

The thermostatted version of all samplers and the fraction collector include the G1330A/B thermostat module. The thermostat module must be placed directly under the sampler or the fraction collector to be thermostatted. It is recommended that the thermostat module is positioned as the bottom module of the stack, directly on the laboratory bench. Any stack containing a G1330A/B thermostat module needs at least 25 cm (10 inches) of space on either side to guarantee proper ventilation.

PLEASE NOTE:

Try to avoid stacking configurations that result in excessive volumes between sampler and column, and between column and detector(s).

Please refer to figures 1, 2, 3,4 and 5 for recommended stacking configurations.



Site Preparation Specification

Figure 1
Recommended 1-Stack Configuration

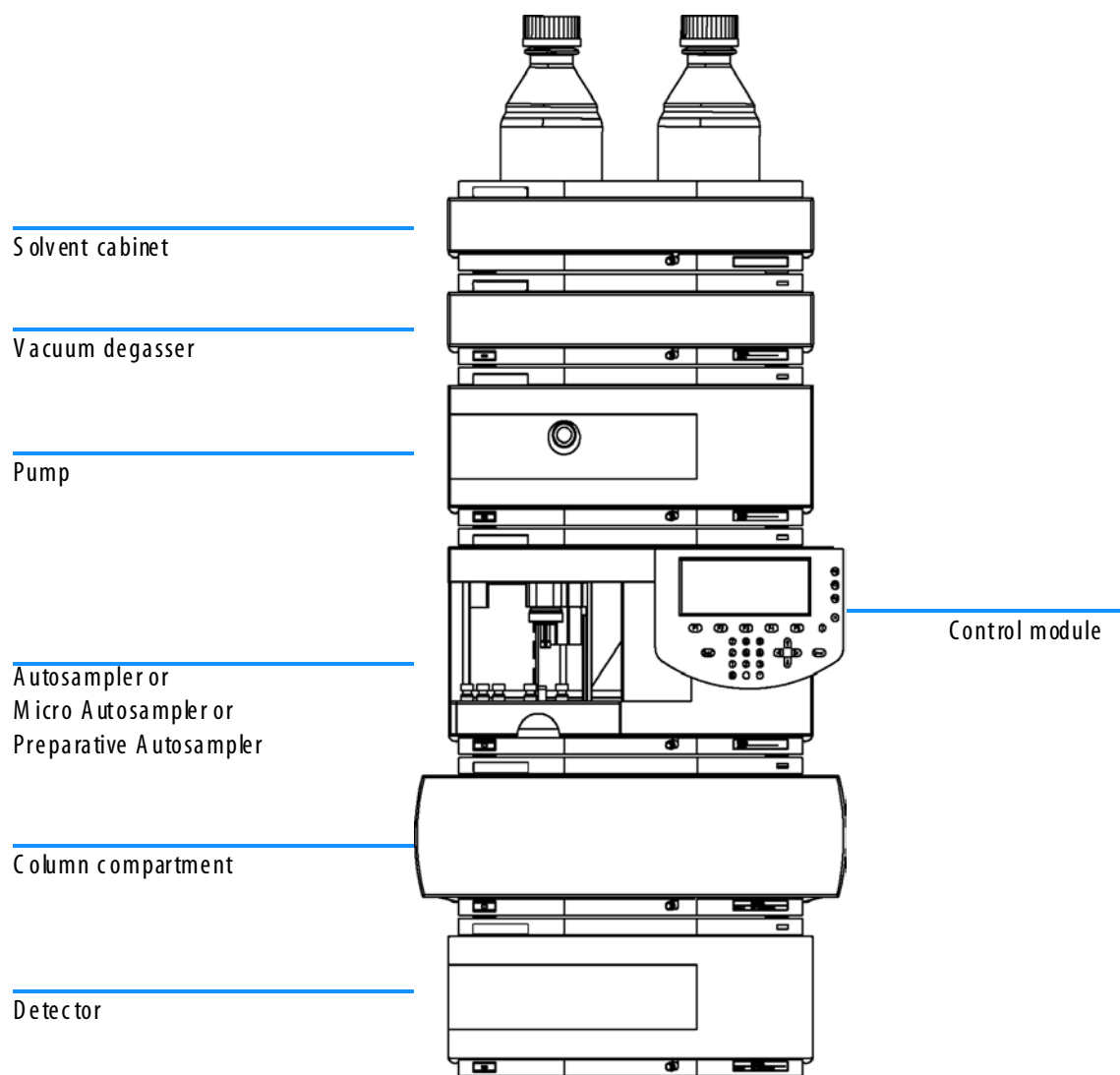



Site Preparation Specification

Figure 2
Recommended 2-Stack Configuration

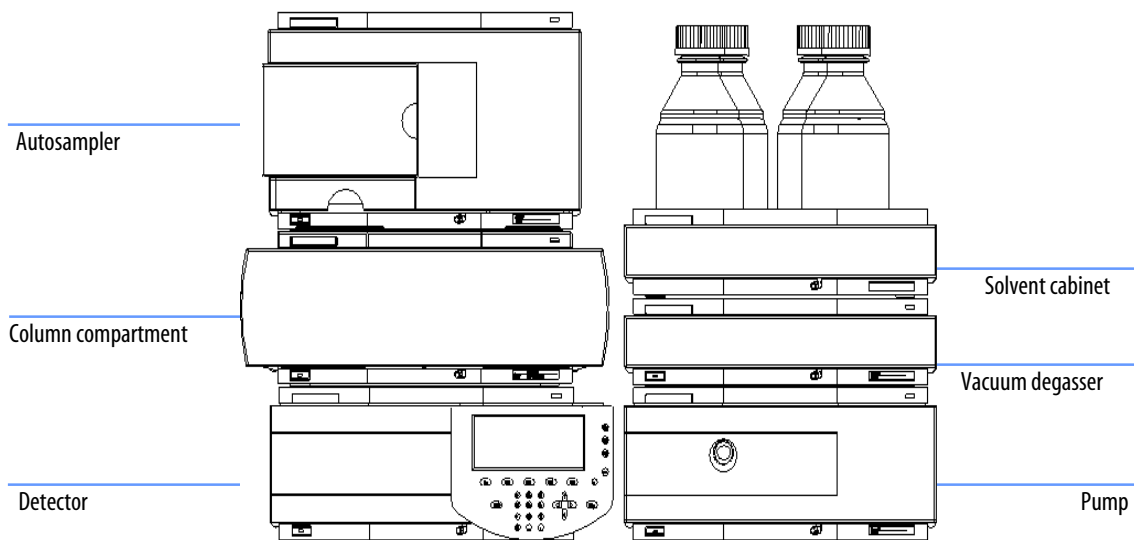



Site Preparation Specification

Figure 3
Recommended 2-Stack Configuration (with Thermostatted Sampler)

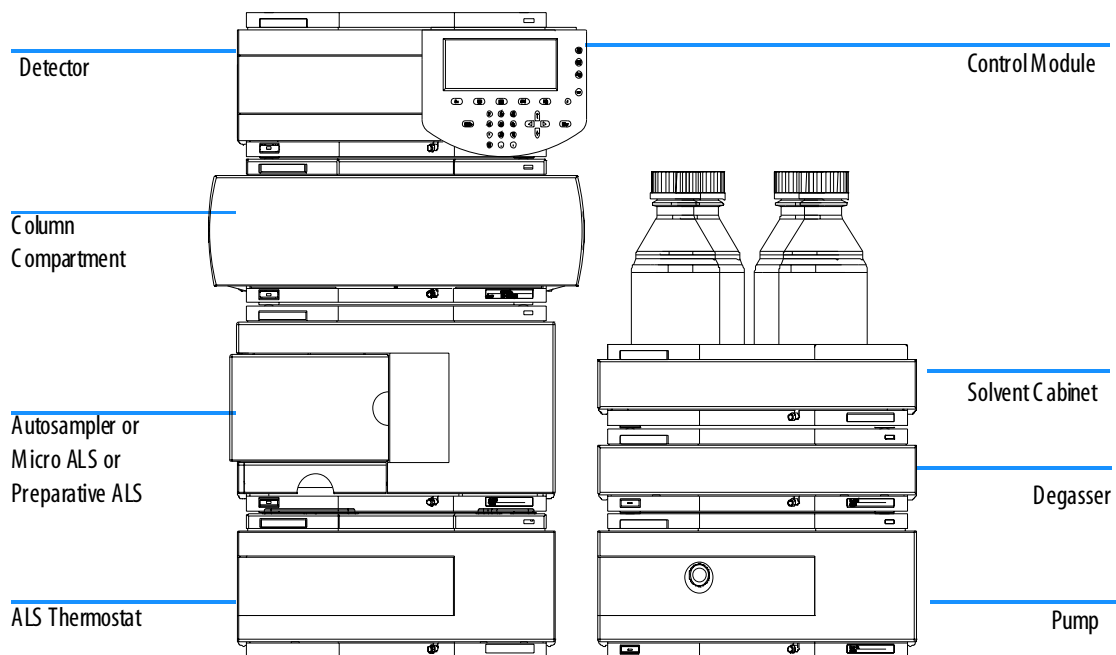



Site Preparation Specification

Figure 4
Recommended 2-Stack Configuration with Fraction Collector (Analytical Scale System)

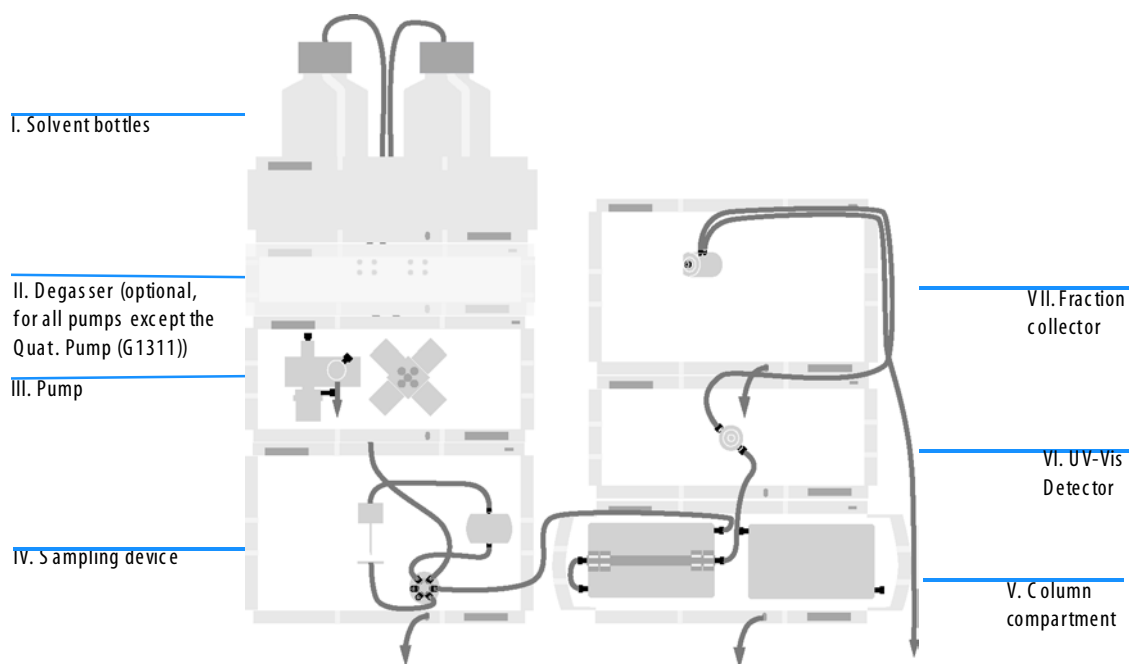

The G1315B and G1365B are operated at an optical unit temperature above ambient conditions for improved baseline stability. If a B-version of the G1315 or the G1365 DAD/MWD is used, the detector should not be placed above the fraction collector! Please reverse the stack containing the fraction collector, when fractionating thermally labile evaporative samples.



Site Preparation Specification

Figure 5
Recommended 2-Stack Configuration with Fraction Collector (Preparative Scale System)

